

HD Centerfire™ Series

Nozzles

Issued Feb. 2008 • Index No. SPEC HDCF-1.0

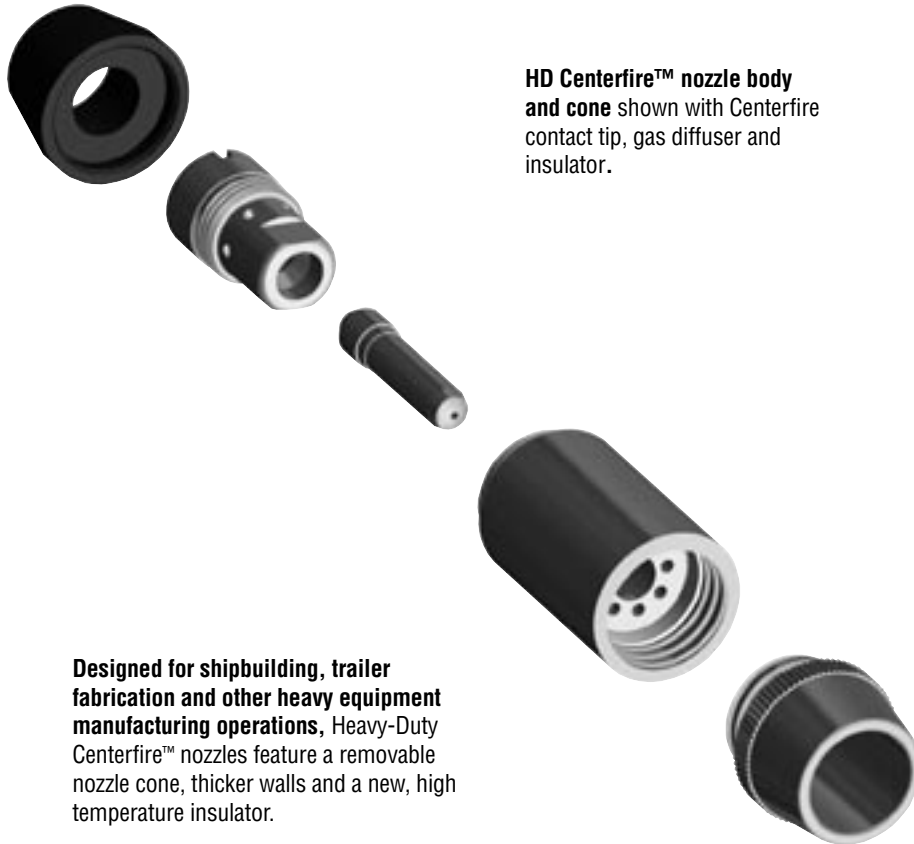

HD Centerfire™ nozzle body and cone shown with Centerfire contact tip, gas diffuser and insulator.

Designed for shipbuilding, trailer fabrication and other heavy equipment manufacturing operations, Heavy-Duty Centerfire™ nozzles feature a removable nozzle cone, thicker walls and a new, high temperature insulator.

All Consumables are Not Created Equal.

It's important to choose longer lasting consumables. They can make the difference between repeated consumable replacement and rework, or more arc time and better bottom line.

Increased wall thickness and new insulating material reduce number of changeovers caused by heat degradation.

Removable nozzle cone lowers downtime and consumables cost by allowing operators to replace only the cone, the most frequently damaged part of the nozzle, without removing and replacing the entire nozzle and contact tip.

Nozzle cleaning made easy - removable cone allows greater access to nozzle body for spatter removal.

Built-in spatter guard produces a calmer gas flow for improved weld puddle protection.

Available in a variety of configurations, with several nozzle orifices and tip recesses.

Fully compatible with standard Centerfire contact tips, gas diffusers and insulating caps.

Fit most competitive brand guns to enhance performance and allow standardization of one contact tip and nozzle for all gun brands to minimize inventory management costs.

Made with
Pride and without
Compromise in the **USA**

Bernard®

An Illinois Tool Works Company
449 West Corning Road, Box 667
Beecher, Illinois 60401 USA

Phone: 800-946-2281 (US Only) 708-946-2281 (Outside US)
Fax: 708-946-6726
For more information, visit us at BernardWelds.com



Available Parts

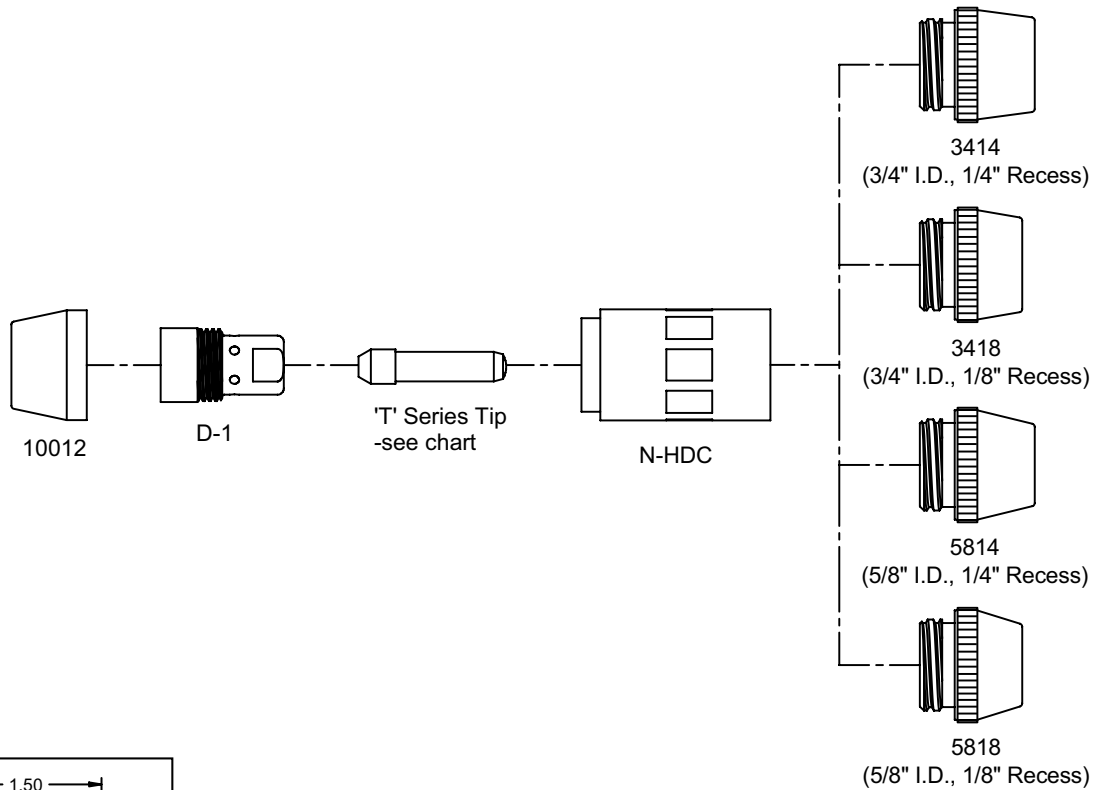

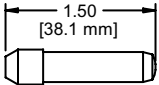
 'T' Series Tip	
T-023	.023" (.6 mm)
T-030	.030" (.8 mm)
T-035	.035" (.9 mm)
T-039	.039" (1.0 mm)
T-045	.045" (1.2 mm)
T-052	.052" (1.4 mm)
T-062	1/16" (1.6 mm)
T-072	.072" (1.8 mm)
T-078	5/64" (2.0 mm)
T-094	3/32" (2.4 mm)
T-109	7/64" (2.8 mm)
T-125	1/8" (3.2 mm)

- Couple the HD Centerfire nozzle body with an HD Centerfire nozzle cone to form a complete HD Centerfire nozzle.
- One nozzle body and one nozzle cone required, order separately.
- Use HD Centerfire nozzles with standard Centerfire 10012 insulator caps, D-1 gas diffusers and 'T' series contact tips.

HD Centerfire™ Nozzle Part Number

Use an HD Centerfire nozzle cone's part number to identify its specifications. The part number below represents an HD Centerfire nozzle cone manufactured with 5/8" I.D. and 1/4" tip recess. The HD Centerfire nozzle body and all nozzle cone's are made of copper.

Nozzle Body	+	Nozzle Cone
N-HDC		5814
<p><i>(i.e. 58 = 5/8" Orifice I.D.)</i> <i>(i.e. 14 = 1/4" Tip Recess)</i></p>		

Competitor Conversion

Simplify parts management and improve performance by converting all of your MIG guns to HD Centerfire nozzles and standard Centerfir

Gun Manufacturer	Gun Model	Gas Diffuser Style	Adapter	Insulator	Gas Diffuser	Contact Tip	Nozzle
Bernard®	Q-Gun, EZ Feed II, G, H, F	Large	Not Required	10012	D-1	Select from table on left	Select from drawing on left
Binzel®	ALPHA 2, ALPHA 3, ALPHA 2 Automatic, ALPHA 3 Automatic	Large	Not Required	4323R	D-1B		
Lincoln®	Magnum 250	Large	1380005	10012	D-1		
	Magnum 300, Magnum 400	Large	Not Required	4423R	D-1T		
Miller®	XR Edge	Large	1380018	10012	D-1		
	XR30A, XR-W, M-25, Roughneck, Python	Large	Not Required	10012	D-1		
OXO®	APX	Large	Not Required	10012	D-1		
Tregaskiss®	Toughgun	Large	Not Required	4423R	D-1T		
Tweco®	160 Mini Mig	Large	1380020	10012	D-1		
	No. 1	Large	1380019	10012	D-1		
	No. 2	Large	1380005	10012	D-1		
	No. 3, No. 4, Tuff-n-Lite, Supra XT (HD Consumables), Spraymaster 450	Large	Not Required	4423R	D-1T		
	No. 5	Large	Not Required	4423R	D-1T-5		
	ELC 250, ELC 350, Spraymaster 250, Spraymaster 350	Large	1380012	10012	D-1		
	ELC 450, EL 450, EL 600, Supra XT (EL Consumables)	Large	1380017	10012	D-1		

Centerfire™ nozzles, tips and gas diffusers are manufactured by Bernard®. Bernard® is the registered trademark of Illinois Tool Works, Inc. Other brands mentioned are for reference only and are the registered trade marks of their respective companies. Illinois Tool Works, Inc. is not affiliated with these other companies.

Installation Instructions

Standard Installation

1. Install insulator cap over neck.
2. Trim liner to between 5/8" and 3/4" beyond neck thread.
3. Torque diffuser onto neck to approx. 12ft-lbs.
4. Insert tip into gas diffuser.
5. Thread nozzle body onto gas diffuser/tip, and tighten firmly by hand.
6. Thread nozzle cone onto nozzle body, and tighten firmly by hand.

Helpful Tip

The base of every Centerfire gas diffuser has a 3/4" diameter, and can be used as a liner trimming guide.



Installation with Conversion Adapter

1. Install conversion adapter.
2. Install insulator cap over conversion adapter.
3. Trim liner to between 5/8" and 3/4" beyond adapter thread.
4. Torque diffuser onto adapter to approx. 12ft-lbs.
5. Insert tip into gas diffuser.
6. Thread nozzle body onto gas diffuser/tip, and tighten firmly by hand.
7. Thread nozzle cone onto nozzle body, and tighten firmly by hand.

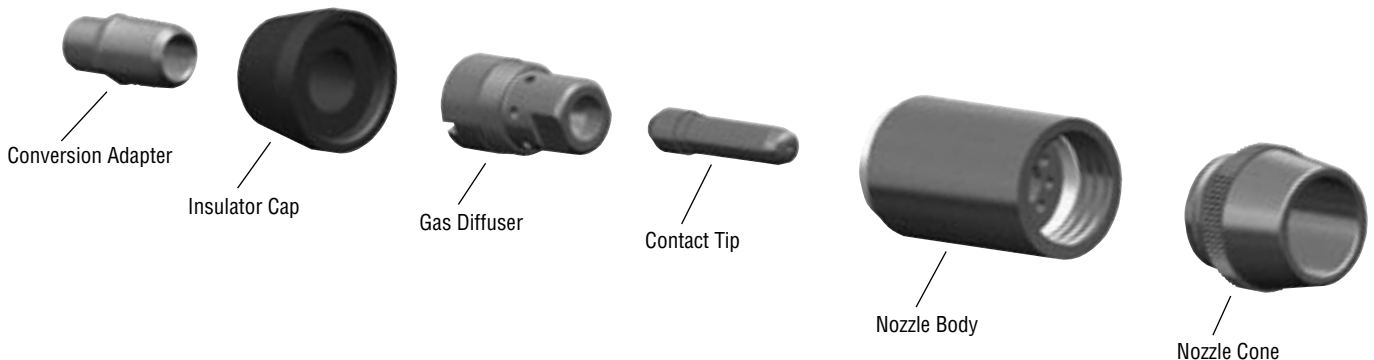

Notes