



OPERATIONS MANUAL

PipeWorx Q-GUN™

Manufactured for Miller Global Pipe Systems

250 Amp

Part Number: 195399

300 Amp

Part Number: 195400

400 Amp

Part Number: 300240



SAFETY DEPENDS ON YOU!

DO NOT INSTALL, OPERATE OR REPAIR THIS EQUIPMENT WITHOUT READING THIS OPERATING MANUAL AND THE ARC WELDING SAFETY PRECAUTIONS ON THE INSIDE FRONT COVER.

Bernard welding equipment is designed and built with safety in mind, but operators must follow prescribed safety guidelines.



Miller Electric Mfg. Co.

An Illinois Tool Works Company
1635 West Spencer Street
Appleton, WI 54914 USA

International Headquarters-USA

USA Phone: 920-735-4504 Auto-Attended
USA & Canada FAX: 920-735-4125
International FAX: 920-735-4125

European Headquarters - United Kingdom

Phone: 44 (0) 1204-593493
FAX: 44 (0) 1204-598066

www.MillerWelds.com

BERNARD® SAFETY PRECAUTIONS

© 2010 Bernard



Some probability of death or serious injury

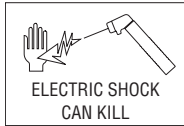

1. Arc welding equipment uses electric energy to create molten bonded metal. Protect yourself and others from possible electric shock/electrocution with proper training and review of safety manuals.
2. Equipment improperly used can cause fatalities.
 - 2.1 Turn off any electrically powered equipment and powered support equipment when not in use. Accidental grounding or activation of equipment can cause circuit completion, electric shock, arc flash, fires, and burns.
 - 2.2 Electrode, torch components, and work surfaces are electrical conductors. These surfaces are 'live' when system is in use.
 - 2.2.1 Typically 'stick' equipment is 'live' when equipment is on. Although modern MIG welding equipment disconnects power from the electrode when not in use, the potential for accidental triggering occurs. Treat all equipment with safety in mind.
 - 2.3 Check for proper termination.
 - 2.3.1 Check for proper grounding and attachments.
 - 2.3.2 Check for proper service termination of input to National Electrical Codes and local codes with trained and certified electricians.
 - 2.3.3 Keep welding ground as close to workpiece as possible.
 - 2.3.4 Inspect torch, holders, cords, clamps, terminators, and cables for frayed wires, defects, and abrasion leading to short circuit conditions or current capacity reductions.
 - 2.3.5 Use proper 'sized' torches, cables, and connections for current being carried. Use of equipment with duty cycle less than expected can lead to premature component degradation and short circuiting.
 - 2.3.6 Never touch two or more electrically 'live' parts together including torches and holders. This compounds open circuit voltage and provides feedback circuits with potential of electrical shock.
 - 2.3.7 Isolate components in automated equipment if possible. Place warning labels on electrically 'live' parts where isolation is not possible.
3. Wear proper safety equipment and clothing.
 - 3.1 Wear proper safety glasses or eye protection should arcing occur.
4. Disconnect power when making any service connections of equipment. 'Lock Out, Tag Out' all circuits and feeds.
5. Falls can be dangerous.
 - 5.1 Keep work area clear as not to trip or fall into open circuits, causing shock.
 - 5.2 When working at levels above ground, protect yourself from shock-causing falls.



Some probability of death or serious injury

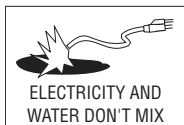

1. Never dip electrode in water for cooling.
2. Do not stand in water or on damp floors while welding, or do not weld in the rain. Avoid wearing wet or sweaty clothes as they provide an easier electric current path to you.
3. Always insulate yourself from the work and ground by wearing proper safety equipment and clothing.
 - 3.1 Isolate yourself from all moist conditions with dry hole-free clothing, gloves, and rubber-soled (nonconductive) shoes. Use a nonconductive platform to isolate yourself from conductors, water, and dampness.
 - 3.2 When welding in damp locations and in awkward positions, such as sitting or lying, make certain insulating material is large enough to cover your full area of physical contact with work and ground.
 - 3.3 Fix water leaks prior to welding, or immediately stop should they occur, and provide proper repair.
4. Keep everything dry including clothing, work area, cables, electrode holder, and power supply.
5. Never handle 'live' electrical or welding equipment with bare hands while standing in water or while hands and/or feet are wet. Dangerous electric shock can result.



Some probability of death or serious injury



1. Where compressed gases are to be used at the job site, special precautions should be used to prevent hazardous situations.
2. Always secure cylinders in an upright position to a fixed support so that they cannot be knocked over. Valve protection caps should always be in place except when cylinder is in use.
3. Locate cylinders clear of areas where they may be struck and safe distance from welding or any other source of heat, sparks, or flame.
4. Cylinders must be handled carefully to prevent damage to their walls, valves, or safety devices. Never lift cylinders by valves or caps.
5. Keep your head and face away from cylinder valve outlet regulator when opening cylinder valves.
6. All regulators, hoses, fittings, etc. should be properly maintained and in good condition as per the manufacturer's recommendations. Faulty equipment should be replaced immediately.
7. Never strike an arc on a cylinder or allow any other electrically 'live' parts to come in contact with a cylinder. This can cause a violent rupture or lead to a rupture during handling.



Some probability of death or serious injury



1. The welding area.
 - 1.1 Remove all fire hazards from the weld area. If this is not possible, move work to a hazard-free area or cover all combustibles with a fire-resistant cover. Bear in mind that hot material and sparks from the welding process easily go through small cracks and openings into adjacent areas.
 - 1.2 Do not weld in areas which have a flammable atmosphere containing explosive gases or vapors. Avoid paint booths, solvent cleaning tanks, ventilators, and storage areas which contain grain or wood dust.
 - 1.3 After welding, turn off all equipment or place gun in a safe location in which no part of the electrode circuit is contacting the workpiece or ground. Accidental engagement could create a fire hazard.
 - 1.4 Keep all equipment clean, free of oil and grease.
 - 1.5 Keep the appropriate fire extinguishing equipment in weld area.
 - 1.6 A fire watcher must be present with the appropriate fire extinguishing equipment and until the area is deemed safe after welding if the following conditions exist:
 - 1.6.1 Combustibles are within the weld area.
 - 1.6.2 Combustibles which can be ignited by sparks are near the weld area.
 - 1.6.3 Openings in the floors, dividers, and walls may expose combustibles to weld sparks.
 - 1.6.4 Combustibles are adjacent to floors, dividers, or walls that could be ignited by radiant or conductive heat.
 - 1.7 After welding has been completed make sure the area is free of glowing embers, sparks, and any flames.
2. Equipment.
 - 2.1 See 'CYLINDERS MAY EXPLODE' section, #2 and #3.
 - 2.2 Periodically check all shielding gas line connections for leaks. Also check the condition of all hoses.
 - 2.3 Keep all protective clothing free of oil and grease.
 - 2.4 Flammable hair preparations should not be used.
 - 2.5 When working with gas-powered equipment, these precautions should be followed:
 - 2.5.1 Turn off engine and allow to cool before refueling.
 - 2.5.2 Carefully refuel equipment to prevent spillage. Wipe up all spilled fuel and do not restart engine until fumes have been eliminated.
 - 2.5.3 Never add fuel near an open flame, when engine is running, or while arc welding.
 - 2.5.4 Do not overfill fuel tank, heat may expand the fuel causing it to overflow and ignite.



Some probability of death or serious injury



1. Illness or death can result from breathing fumes, gases, or oxygen enrichment or depletion that welding may produce.
2. Provide proper ventilation to avoid breathing fumes and gases produced by welding. It may be necessary to supply fresh air to the welder with an air-supplied respirator or other means when working in a confined space.
3. The three major toxic gases associated with GMAW are ozone, nitrogen dioxide, and carbon monoxide.
4. Do not weld near degreasing or other cleaning operations involving chlorinated hydrocarbons. Heat and arc rays can react with solvent vapors and form phosgene, a highly toxic gas, along with other irritating products.
5. Shielding gases can displace air. Use special care to insure that breathing air is safe when welding in confined area. Upon entering a confined space, check the breathing air to make sure it is safe. Check gas connections for leaks after installation and regularly thereafter.
6. If welding causes dizziness, nausea, or respiratory irritation, ventilation is inadequate.
7. Operate engine-powered equipment in open, well-ventilated areas or exhaust the engine's fumes outdoors. Never ventilate with oxygen.
8. Read and understand the manufacturer's instructions for this equipment and other welding equipment. This includes the Material Safety Data Sheets (MSDS) and your employer's safety practices.

3. Wear suitable clothing to reduce risk of burns to exposed skin.
 - 3.1 Wear durable, flame-resistant clothing with closed, opaque weaves. This reduces chance of 'sun' burn, contact burns, and accidental ignition of clothing that could occur.
 - 3.1.1 Do not wear wet or damp clothing.
 - 3.2 Wear appropriate gloves, shoes, and outer protection as described to prevent electrical shock.
4. Protect others from arc rays that can burn unintentionally.
 - 4.1 Provide suitable screening to reduce exposure of others to existing welding areas.
 - 4.2 Provide proper eye protection.
 - 4.3 Provide suitable clothing.



Minor personal injury or damage to equipment



1. Improperly balanced equipment can result in personal injury and/or damage to equipment.
2. Check and maintain equipment daily for safe operation.
3. Read and understand the manufacturer's instructions for this equipment and other welding equipment. This includes your employer's safety practices.



Some probability of death or serious injury



1. Keep clothing, tools, hands, fingers, or any other part of your body away from moving parts of the machine such as v-belts, gears, and fans.
2. Never operate any equipment without safety guards.



For most efficient operation



1. Material Safety Data Sheets are designed to help you understand how to safely work with chemicals and materials in your work area.
 - 1.1 Follow data sheet instructions for proper ventilation or respiration.
 - 1.2 Follow proper first aid treatment should accidents occur.
 - 1.3 Keep proper fire extinguishing equipment as denoted on data sheet.
 - 1.4 Do not exceed exposure limits.
 - 1.5 Dispose of material properly.
2. Read and understand data sheets regarding the hazards associated with the use of chemicals and materials.



Minor personal injury or damage to equipment

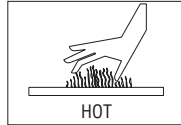

1. Hot metal such as electrode stubs and workpieces should never be handled.
 - 1.1 Serious burns and injury can occur from accidental contact with hot materials.
 - 1.2 Wear protective clothing to prevent burns to exposed skin.
 - 1.2.1 Wear insulated gloves.
 - 1.2.2 Wear clothing that resists heat penetration and ignition.
 - 1.3 Assume that all metal pieces in the weld area are hot.
2. If touching, always test any metal and discarded electrodes for heat. Do not assume any material in the welding area is cool to touch.
3. Mark welded work HOT or place small pieces in marked container.

SAFETY REFERENCES

- AWS Z49.1 (ANSI) "Safety in Welding and Cutting"
 AWS C5.6 "Recommended Safe Practices for Gas-Metal Arc Welding"
 AWS F4.1 "Recommended Safe Practices for the Preparation for Welding and Cutting of Containers and Piping"
 AWS C5.1 "Recommended Practices for Plasma Arc Welding"
 AWS C5.3 "Recommended Practices for Air Carbon Arc Gouging and Cutting"
Available from the American Welding Society, P.O. Box 351040, Miami, Florida 33135
- ANSI Z41 "Standard for Personal Protection - Protective Footwear"
 ANSI Z49.1 "Safety in Welding and Cutting"
 ANSI Z87.1 "Practice for Occupational and Educational Eye and Face Protection"
 ANSI Z88.2 "Standard Practice for Respiratory Protection"
Available from the American National Standards Institute, 11 W. 42nd St., New York, NY 10036
- Code of Federal Regulations (OSHA)
 Section 29, Parts 1900-1910.999 and 1910.1000-
Available from the U.S. Government Printing Office, Washington, DC 20402
- CSA W117.2 "Safety in Welding, Cutting, and Allied Processes"
Available from the Canadian Standards Association, 178 Rexdale Blvd., Rexdale, Ontario, Canada M9W 1R3
- CGA Pub. P-1 "Safe Handling of Compressed Gas in Containers"
Available from the Compressed Gas Association, 1725 Jefferson Davis Highway, Arlington, VA 22202-4100
- NFPA51B "Fire Prevention in Cutting and Welding Processes"
 NPFA70 "National Electrical Code"
Available from the National Fire Protection Association, Batterymarch Park, Quincy, MA 02269



Minor personal injury or damage to equipment

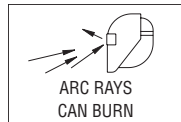

1. The welding arc produces a bright light emitting concentrated volumes of ultraviolet and infrared rays. These rays are harmful to unprotected eyes or skin. Protection shall be taken to inhibit exposure.
2. Protect eyes from arc rays.
 - 2.1 Do not observe the arc or its reflection without eye protection including filtered lenses.
 - 2.1.1 Filters with cover plates shall be worn to reduce exposure to rays.
 - 2.1.2 Cracked or broken lenses should be replaced immediately, reducing risk of unfiltered light entry into eyes.
 - 2.2 Protect face area from arc rays by using proper hooding and shields.
 - 2.2.1 Hood shall be opaque.
 - 2.2.2 Hood shall be replaced immediately, reducing risk of unfiltered light entry, should cracks or holes occur.

BERNARD® SAFETY PRECAUTIONS CONTINUED...

© 2010 Bernard

EMF Information

Considerations About Welding And The Effects Of Low Frequency Electric And Magnetic Fields

Welding Current, as it flows through welding cables, will cause electronic magnetic fields. There has been and still is some concern about such fields. However, after examining more than 500 studies spanning 17 years of research, a special blue ribbon committee of the National Research Council concluded that: "The body of evidence, in the committee's judgment, has not demonstrated that exposure to power frequency electric and magnetic fields is a human-health hazard." However, studies are still going forth and evidence continues to be examined. Until the final conclusions of the research are reached, you may wish to minimize your exposure to electromagnetic fields when welding or cutting.

To reduce magnetic fields in the workplace, use the following procedures:

1. Keep cables close together by twisting or taping them.
2. Arrange cables to on side and away from the operator.

3. Don not coil or drape cables around your body.
4. Keep Welding power source and cables as far away from operator as practical.
5. Connect work clamp to workpiece as close to the weld as possible.

About Pacemakers:

Pacemaker wearers consult your doctor first. If cleared by your doctor, them following the above procedures is recommended.

California Proposition 65 Warning

This product contains chemicals, including lead, known to the state of California to cause cancer, and birth defects or other reproductive harm. *Wash hands after use.*

Introduction

Thank you for choosing Bernard. The product you have purchased has been carefully assembled and factory tested prior to shipment. Should you experience problems with installation or performance, please refer to the "Troubleshooting Guide" in this manual.

Before installing, compare the equipment received against the invoice to verify that the shipment is complete and undamaged. It is the responsibility of the purchaser to file all claims of damage or loss that may have occurred during transit with the carrier.

The manual contains general information on the operation of this Bernard product. Before installing or operating any equipment, read and understand the information and safety precautions presented in this manual. Also, note the various data plates, labels, and tags attached to the product.

While every precaution has been taken to assure the accuracy of this manual, Bernard assumes no responsibility for errors or omissions. Bernard assumes no liability for damages resulting from the use of the information contained herein. Bernard shall have no liability to the buyer for consequential damages or be liable to the in tort for any negligent manufacture of the goods or for the omissions of any warning therefrom.

Part I General Description

The Bernard PipeWorx gun is designed primarily for processing mild steel electrode under GMAW (Gas Metal Arc Welding), MIG (Metal Inert Gas), MAG (Metal Active Gas), FCAW (Flux Cored Arc Welding), and MOG (Metal without Gas).

The PipeWorx gun provides rapid body tube interchangeability, typically during production processes. Body tube may also be positioned on line within a 360 degree rotation. This position allows for movements between standard horizontal welding, overhead, and hard-to-reach side angles. The body tube includes an optional jump liner system that effectively reduces costs associated with one-piece liner systems. Bernard is concerned about your higher productivity.

Commercial Warranty

Product is warranted to be free from defects in material and workmanship for 180 days after the sale by an authorized Buyer.

Bernard reserves the right to repair, replace or refund the purchase price of non-conforming product. Product found not defective will be returned to the Buyer after notification by Customer Service.

Bernard makes no other warranty of any kind, expressed or implied, including, but not limited to the warranties of merchantability or fitness for any purpose. Bernard shall not be liable under any circumstances to Buyer, or to any person who shall purchase from Buyer, for damages of any kind. Including, but not limited to any, direct, indirect incidental or consequential damages or loss of production or loss of profits resulting from any cause whatsoever, including, but not limited to, any delay, act, error or omission of Bernard.

Genuine Bernard parts must be used for safety and performance reasons or the warranty becomes invalid. Warranty shall not apply if accident, abuse, or misuse damages a product, or if a product is modified in any way except by authorized Bernard personnel.

The PipeWorx gun meets or exceeds NEMA (National Electrical Manufacturer's Association) EW3 requirements for torches used in a wide variety of applications including aluminum, silicone bronze, and hard facing alloys to name a few. With Bernard's flexibility, many applications can be accommodated with field installed options increasing performance and maneuverability.

Part II Installation

1. Your torch has been shipped with a specific feeder connector, body tube, and sized for electrode as per the part number indicated on its package. Please inspect the received torch against this part number for accuracy.
2. Turn off power prior to any installation.
3. Fully extend gun and cable. Press liner fully into power pin.
4. Safely expose approximately 2" (51 mm) of electrode beyond feeder or adaptor block.
5. **Direct Plug**
Connect the power pin of the direct plug torch by sliding the electrode into the liner and the power fitting into the drive housing of the feeder. Fully seat the unit in position and tighten into place as designated in the manufacturer's instructions. On initial installations, a thin film of silicone lubricant will aid installation and prevent o-ring damage.

Attach control lead wires to the appropriate plug, terminals, or lead kit. Plug or wire into the control circuit of the feeder as designated in manufacturer's instructions.

If a gas hose is provided, connect to the feeder's solenoid circuit to deliver shielding gas to the arc. If no gas hose is provided, gas is delivered through the power pin. Refer to the manufacturer's instructions for proper gas connection at the feeder block or solenoid.
6. Remove nozzle from head assembly.
7. Pull tip from head/gas diffuser. An unobstructed electrode path has now been established.
8. Safely feed electrode through the torch and approximately 1" (25 mm) beyond head/gas diffuser.
9. Reinstall the tip over the electrode and lock into position by reinstalling the nozzle.



Welding current and duty cycle shall not exceed published specification of this product. If such conditions exist, product life and performance will be reduced.

Part III Helpful Operating Tips

Nozzles:

1. If anti-spatter is used, do not coat nozzle insulator as this may degrade insulating material.
2. Nozzle should be cleaned as often as possible. Spatter buildup can often lead to poor gas shielding or short circuiting between the contact tip and the nozzle.
3. Spatter should be removed with the proper tools designed for spatter removal.
4. In high temperature welding applications, heavy duty consumables are recommended.

Contact Tips, Head/Gas Diffusers:

1. Contact tips may be removed and rotated in head/gas diffuser, providing an additional wear surface and extending the service life of the product.
2. Inspect nozzle for spatter adhesion, blocked gas ports, and carburized contact surfaces. Clean as often as possible.
3. If anti-spatter is used, periodically check gas ports for blockage.

4. When using dual shield electrode, periodically check gas ports in head/gas diffuser for clogging caused by flux from within the electrode.

Cable:

1. Periodically check torques of body tube and end fittings. Loose fittings can cause overheating and premature failure of the gun.
2. Sharp bends and loops in the cable should be avoided. Often the best solution is to suspend the wire feeder from a boom or trolley, thus eliminating a large number of bends and keeping the cable clear of hot weldments.
3. Do not immerse liner into solvents for cleaning; the liner may be periodically blown out with compressed air.
4. Avoid rough surfaces and sharp edges that can cause tears and nicks in cable jacket which can cause premature failure.
5. Periodically check all cables and ground connections.
6. Use anti-seize on all threaded connections.

Part III Helpful Operating Tips (cont.)

Feeder:

1. Check drive rolls for wear; be sure drive rolls and guide tubes are clean and free of debris. Do not overtighten drive rolls; set as per manufacturer's specifications.
2. Use clean, non-corroded electrode.
3. When installing or replacing electrode, you may: remove burrs from end of electrode, remove head/gas diffuser and tip, and/or straighten the first few inches of electrode.

End User Stocking Recommendations:

Nozzles.....	5 for every 1 gun in service
Tips	30 for every 1 gun in service
Head/Gas Diffusers	4 for every 1 gun in service
Triggers.....	1 for every 10 guns in service
Body Tubes	1 for every 20 guns in service
Handle Kits.....	1 for every 20 guns in service
Replacement Cables.....	1 for every 20 guns in service
Strain Relief Kits	1 for every 20 guns in service
Adaptor Kits	Order as Necessary
Direct Plug Kits	Order as Necessary

These stocking recommendations are only initial guidelines based on an 80 hour work period. You should work closely with your distributor to tailor a stocking program that suits your specific needs. Results will vary.

Part IV Maintenance and Repair

See pages 6 and 7 for parts lists

CAUTION

Disconnect gun from equipment, allow to cool, and remove electrode from liner before servicing.

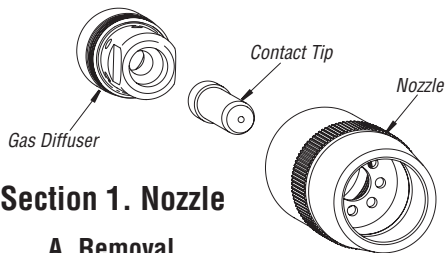

FIGURE #1

Section 1. Nozzle

A. Removal

Threaded fit nozzle can be removed by turning in a counterclockwise direction.

B. Service

Inspect nozzle for cracks and degradation of insulation. Clean the nozzle as often as possible to prevent spatter build-up which can lead to poor gas shielding or short circuiting. Replace the nozzle when loose, worn, or producing erratic gas shield.

C. Installation

Replace threaded fit nozzle by threading in a clockwise direction. Nozzle body is used to secure contact tip.

Section 2. Contact Tip

Bernard has designed Centerfire contact tips to allow rapid installation and adjustment.

A. Removal

Cut electrode and remove all burrs. Remove threaded fit nozzle by turning in a counterclockwise direction. Pull the Centerfire tip from head/gas diffuser.

B. Service

To extend contact tip life, reface front of tip and clean the bore. Tips may be rotated in gas diffuser/head socket providing additional wear surface and extending the service life of the product.

C. Installation

Replacement is accomplished by cutting electrode and removing all burrs. Slide tip over electrode into gas diffuser head and replace threaded fit nozzle by threading in a clockwise direction. Nozzle body is used to secure contact tip.

Section 3. Head/Gas Diffuser

A. Removal

The head may be removed with an appropriate wrench in a counterclockwise rotation.

B. Service

Inspect head for spatter, blocked gas ports, and carburized surfaces. Clean as often as possible. Replace with new head when wear prevents engagement of contact tip or nozzle.

C. Installation

Firmly secure head with an appropriate wrench in a clockwise rotation, torque to 70 in-lbs. Be sure insulator cap is in place as shown in figure #1.

Section 4. Body Tube

A. Removal

Grasp lock nut and rotate counterclockwise, rotation will free body tube from end fitting.

B. Installation

Before installing, inspect body tube and end fitting for debris, clean if necessary. Install body tube in reverse order, torque to 31-41 in-lbs. NOTE: Refer to Jump Liner literature for liner cut off sizes (if used).

Part IV Maintenance and Repair (cont.)

Section 5. Jump liner (Optional)

A. Removal

Remove nozzle, head/gas diffuser and body tube. Remove used jump liner from the back end of body tube.

B. Service

Inspect for excessive wear and debris on the inside diameter. Do not dip jump liner in solvents for cleaning. Jump liners may be periodically blown out with shop air. Replace with new jump liner when excessive wear or debris produces poor electrode feed.

C. Installation

Insert jump liner making sure the liner stop is fully seated at the back of the body tube. Take the tapered end of the body tube and insert into end fitting of the gun handle. Install the body tube. Trim and deburr the liner past the nozzle end of the body tube.

Install head/gas diffuser and nozzle.

Section 6. Handle

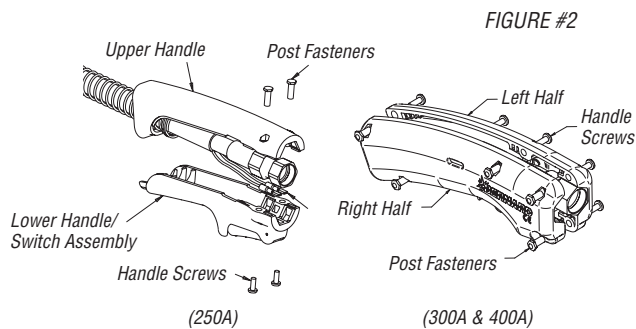

A. Removal

Remove screws, post fasteners. Separate and remove handle halves.

B. Service

Inspect for cracks, deformation of hex areas, debris, holes, loose or missing threaded inserts, excessive wear, exterior heat deformation, and warpage. If any of the above conditions exist, replace with new handle or clean all surfaces with mild detergent and reinstall. Test switch for continuity. Clean any debris from trigger, if necessary, replace with new trigger handle assembly.

C. Installation

Position cable in handle half. Pressing lead wire terminal fully into terminals of switch. Position remaining handle half so leads are not pinched and movement of the trigger is not impaired. Post fasteners, and screws; torque to 10 in-lbs (1.1 Nm)

Section 7. Cable

A. Inspection

Replace the cable assembly if the following conditions are evident on the exterior of the cable: cuts and/or abrasions in cable jacketing exposing copper stranding, abrupt kinking of cable causing abnormal heating in area of bend, loss of control circuit function as verified through continuity tests, slippage of insulating jacket exposing copper stranding, or crushed cable.

B. Replacement

Using a replacement cable, install the terminated cable end to the adapter block. It will be necessary to install or confirm that the flexible strain relief and cap is in place before preparation (See Figure 3).

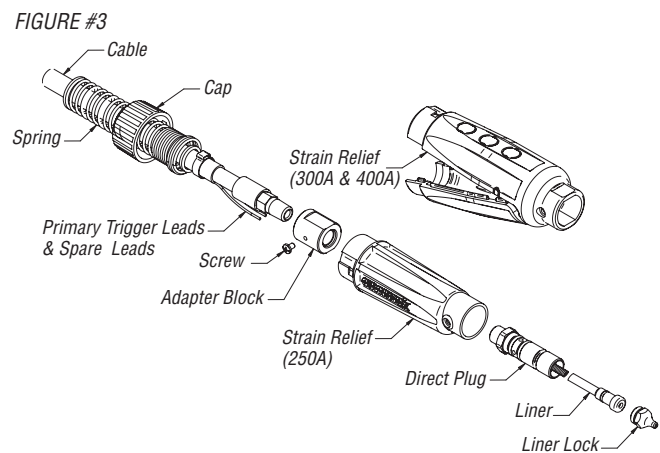

Torque the end fitting into the adapter block to 17 ft-lbs (23 Nm). Strip the appropriate control leads 1/4" (6.4 mm) and crimp to appropriate butt connections of trigger leads. Finalize installation.

C. Repair

There is no authorized repair of welding cable due to product liability. Control leads may be repaired by splicing high temperature 18 AWG lead wire with nylon coated butt connectors, or spare leads can be used.

Section 8. Liners

A. Removal

Remove nozzle and head/gas diffuser

Guns with jump liner: Remove body tube. Lay cable straight. Grasp liner lock which protrudes from power pin (some direct plugs may require removal of additional components to access the liner lock) and remove from cable assembly.

B. Service

Inspect for excessive wear and debris on the inside diameter. Do not dip liner in solvents for cleaning. Liner may be periodically blown out with shop air. Replace with new liner when excessive wear or debris produces poor electrode feed.

Part IV Maintenance and Repair (cont.)

C. Installation

Insert liner into power pin with cable laying straight. Continue until liner lock is fully seated into power pin. A twisting motion may be necessary to seat o-ring (some direct plugs may require installation of additional components to secure liner).

Making sure cable is straight, trim and deburr liner flush with top of installed Centerfire head/gas diffuser.

When using Jump Liner: Trim and deburr liner with 1/4" (6.4 mm) extending beyond the gun handle. Install body tube.

Install head/gas diffuser and nozzle.

Section 9. Rigid Strain Relief

A. Removal

Using a counterclockwise motion, unseat cap and sleeve assembly from rigid strain relief. Remove screw securing strain relief to adapter block.

B. Service

Inspect all components for cracks, debris, excessive wear and breakage. Replace with new components if safety or performance of product is compromised.

C. Installation

Align flats in rigid strain relief with flats on adapter block. Slide strain relief onto adapter block and install screw. Torque screw to 12 in-lbs (1.4 Nm). Using the arrows on the cap to align with mating grooves, slide the cap and sleeve assembly toward the rigid strain relief until seated, and turn clockwise until engaging snap is felt.

Miller Direct Plugs

A. Removal

Remove the power pin tip that retains the liner from the power pin with the appropriate wrench. Remove liner and rigid strain relief from gun assembly. Position control lead wires as necessary as not to damage them. Remove power pin from adapter block using appropriate wrenches in a counterclockwise rotation (See Figure 3).

FIGURE #3

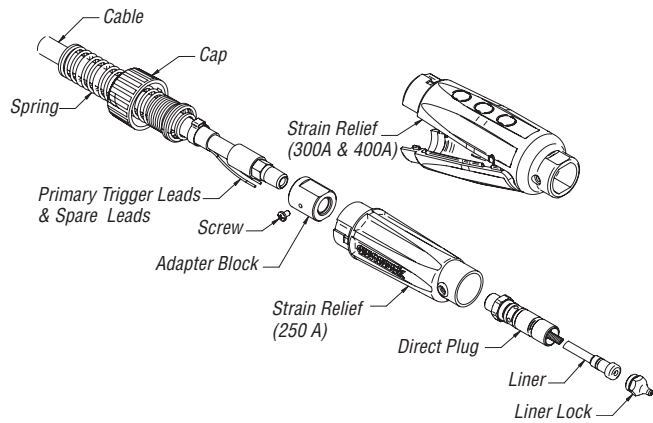

B. Service

Test lead wires for continuity when trigger is engaged. Lubricate o-rings with silicone lubricant. Inspect all components for cracks, debris, excessive wear, and breakage. Replace with new components if safety or performance of product is compromised.

C. Installation

Assemble power pin onto adapter block in a clockwise rotation using appropriate wrenches. Torque to 13 ft-lbs (17.6 Nm)

Install liner. Install power pin tip and tighten to retain liner assembly (See Figure 3).

Part V 250 Amp Gun Exploded Diagram and Parts List

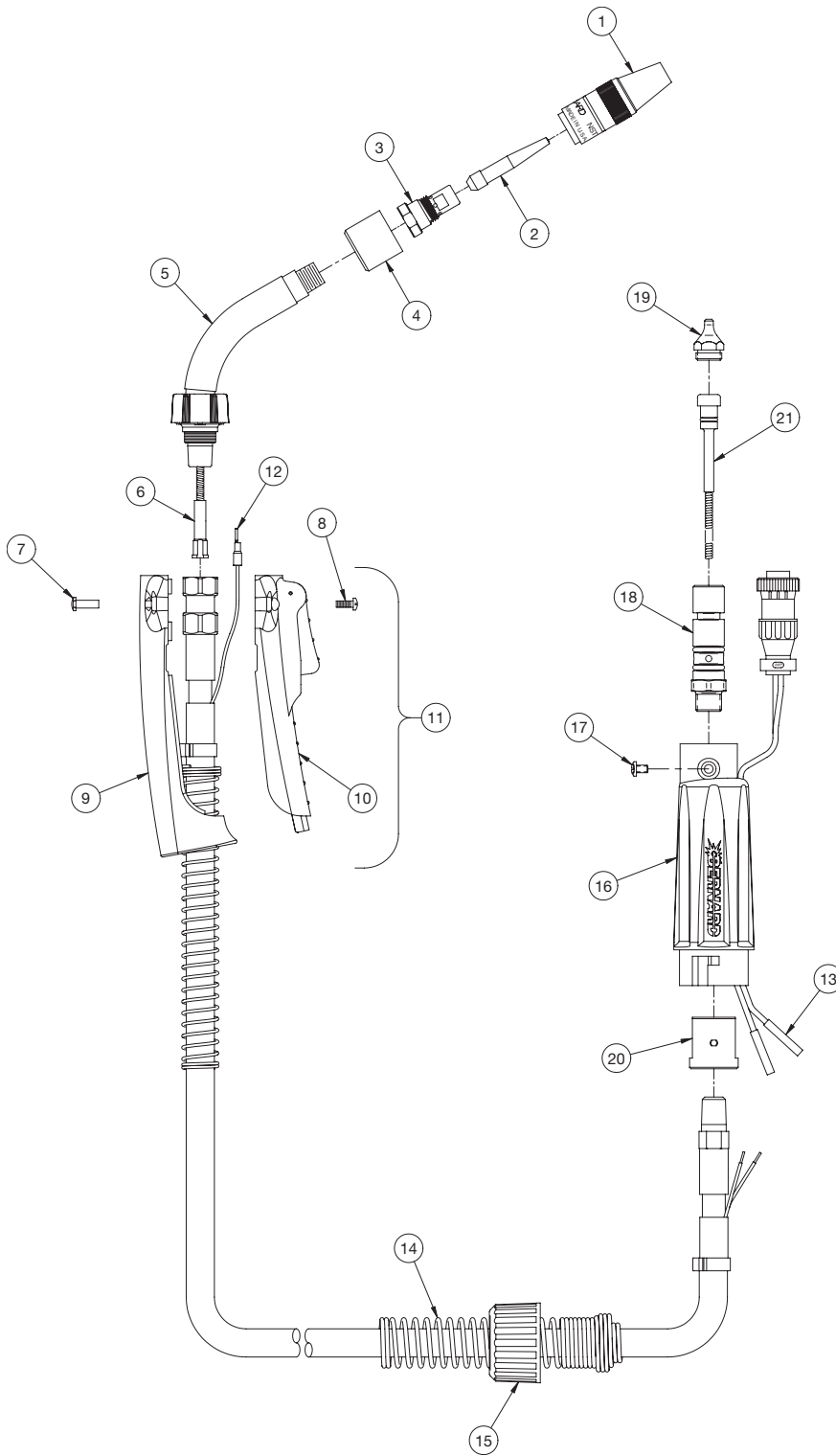

Item	Part Number	Description
1	NST-3800B	Nozzle
2	TT-035	Contact Tip
3	DS-1	Diffuser
4	4323R	Cap
5	QT2-60	Body Tube
6	QJL-3545	Jump Liner
7	4207	Post Fastener
8	4209	Screw
9	1780062	Handle Half, Upper
10	2620054	Switch Assy. & Lower Handle Half
11	1880194	Handle Kit (items 7-10)
12	2660001	Terminal
13	4932	Butt Connector
14	2520048	Spring
15	2520007	Cap, Strain Relief
16	2520047M	Strain Relief Assy. (with plug)
17	W11127-002	Screw
18	2200101	Power Pin Assy.
19	4477	Power Pin Tip
20	1010027	Adapter Block
21	43115	Liner

Part V 300 Amp Gun Exploded Diagram and Parts List

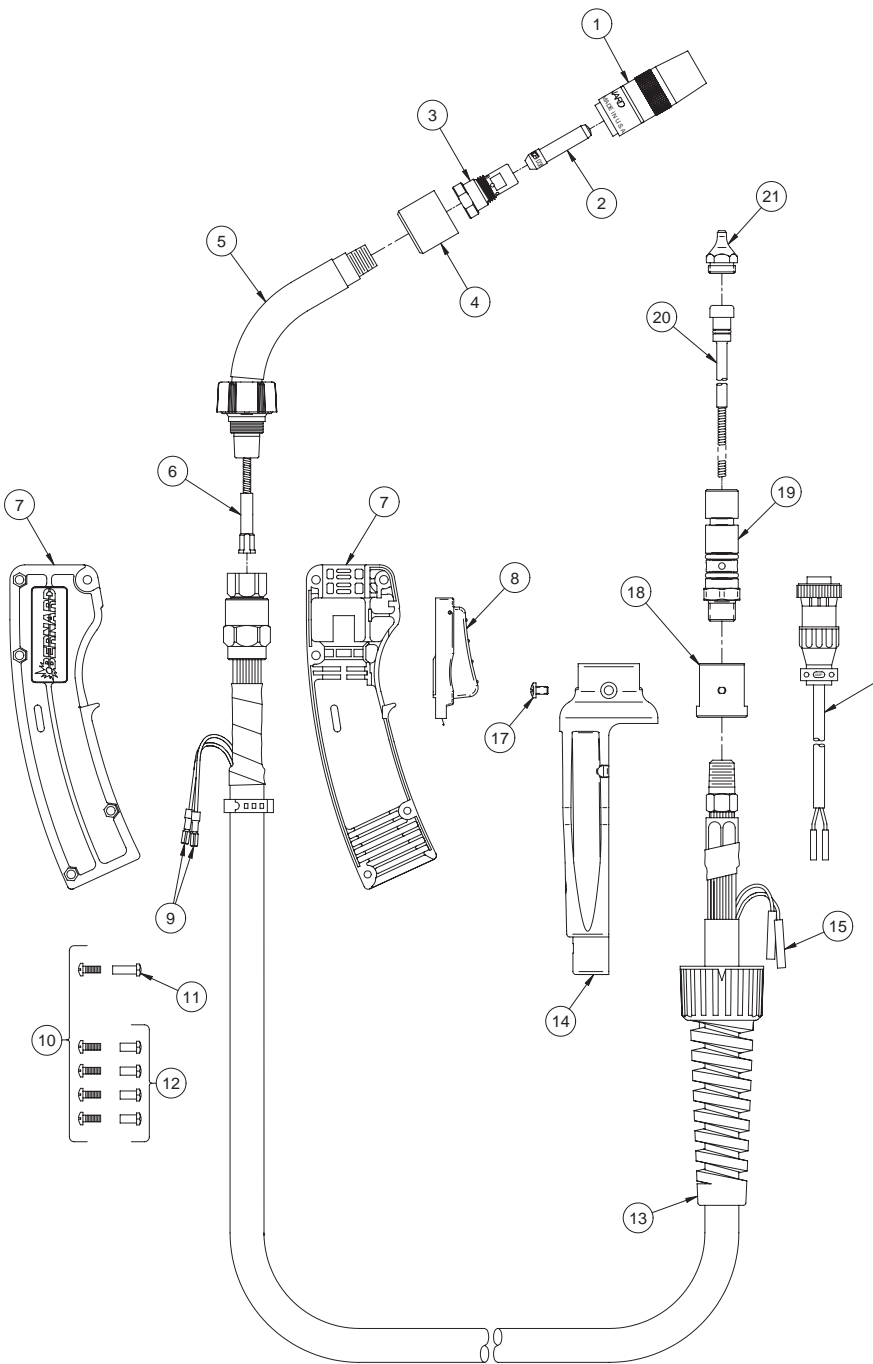

Item	Part Number	Description
1	NS-5818C	Nozzle
2	T-045	Contact Tip
3	DS-1	Diffuser
4	4323R	Cap
5	QT2-60	Body Tube
6	QJL-3545	Jump Liner
7	1880155	Handle Kit (Incl. Handle & Items 10, 11, 12)
8	5662	Trigger
9	2660001	Terminal
10	4209	Screw
11	4207	Post Fastener, Long
12	2030004	Post Fastener, Short
13	2520033	Strain Relief
14	2520066	Strain Relief Set
15	4932	Butt Connector
16	GN2021	Electrical Connection
17	W11127-002	Screw
18	1010027	Adapter Block
19	2200101	Power Pin Assy.
20	43115	Liner
21	4477	Power Pin Tip

Part V 400 Amp Gun Exploded Diagram and Parts List

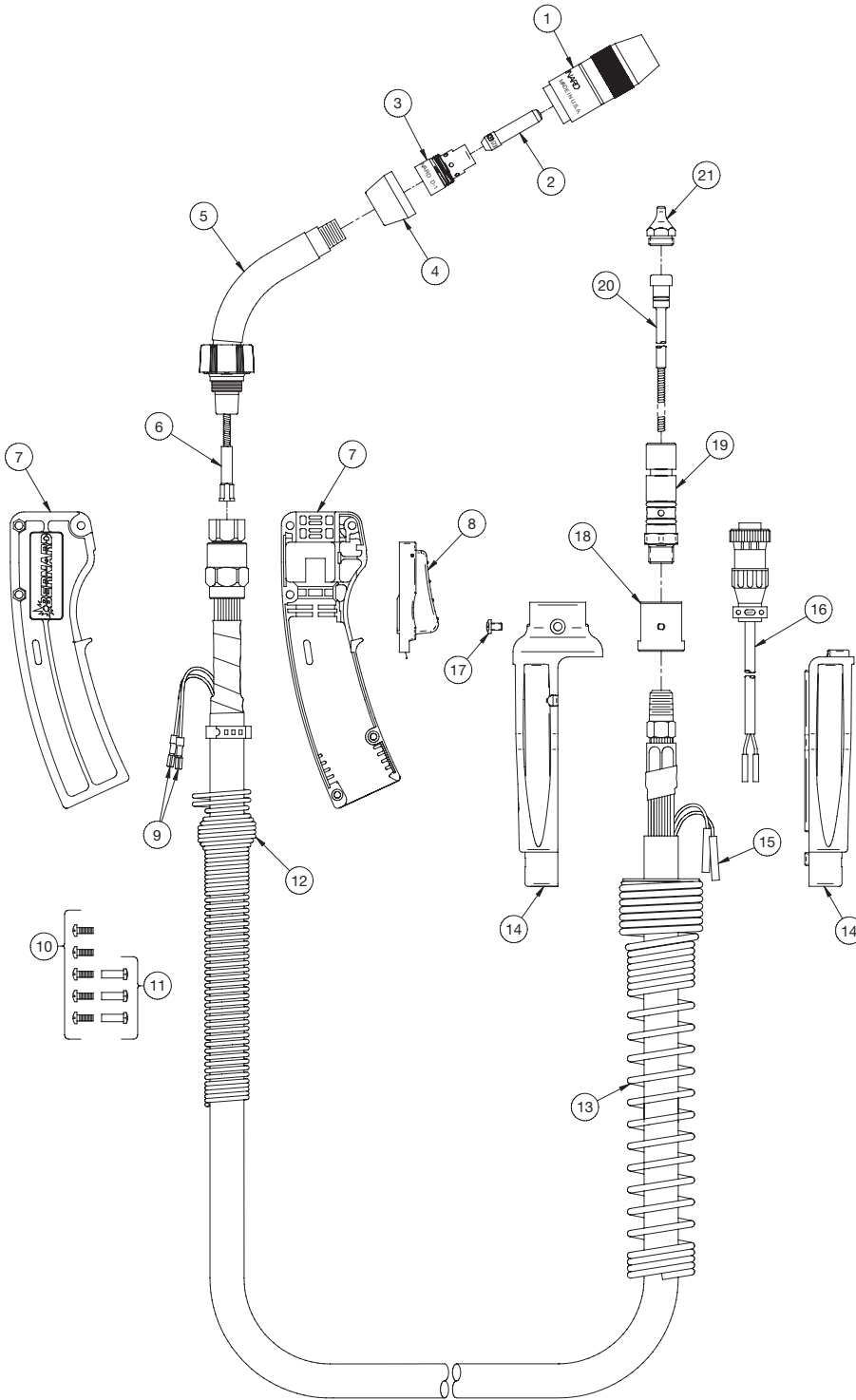

Item	Part Number	Description
1	N-5818C	Nozzle
2	T-045	Contact Tip
3	D-1	Diffuser
4	10012	Cap
5	QT2-60	Body Tube
6	QJL-3545	Jump Liner
7	1880198	Handle Kit (Incl. Handle & Items 10, 11)
8	5662	Trigger
9	2660001	Terminal
10	4209	Screw
11	4207	Post Fastener, Long
12	2520042	Handle Spring
13	2520041	Strain Relief
14	2520066	Strain Relief Set
15	4932	Butt Connector
16	GN2021	Electrical Connection
17	W11127-002	Screw
18	1010027	Adapter Block
19	2200101	Power Pin Assy.
20	43115	Liner
21	4477	Power Pin Tip

Part VI Troubleshooting Guide

PROBLEM	POSSIBLE CAUSE	CORRECTIVE ACTION
1. Electrode does not feed.	<ol style="list-style-type: none"> 1. Feeder relay. 2. Broken control lead. 3. Poor adaptor connection. 4. Worn or broken switch. 5. Improper drive roll size. 6. Drive roll tension misadjusted. 7. Burn back to contact tip. 8. Wrong size liner. 9. Buildup inside of liner. 	<ol style="list-style-type: none"> 1. Consult feeder manufacturer. 2. a. Test & connect spare control lead. b. Install new cable. 3. Test & replace leads and/or contact pins. 4. Replace. 5. Replace with proper size. 6. Adjust tension at feeder. 7. See 'Contact Tip Burn Back'. 8. Replace with correct size. 9. Replace liner, check condition of electrode.
2. Contact tip burn back.	<ol style="list-style-type: none"> 1. Improper voltage and/or wire feed speed. 2. Erratic wire feeding. 3. Improper tip stickout. 4. Improper electrode stickout. 5. Faulty ground. 	<ol style="list-style-type: none"> 1. Set parameters. 2. See 'Erratic Wire Feeding'. 3. Adjust nozzle/tip relationship. 4. Adjust torch to base metal relationship. 5. Repair all cables & connections.
3. Tip disengages from head.	<ol style="list-style-type: none"> 1. Worn head. 2. Improper tip installation. 3. Extreme heat or duty cycle. 	<ol style="list-style-type: none"> 1. Replace tip and/or head. 2. Install as per 'Maintenance & Repair' (Section 2). 3. Replace with heavy duty consumables as per 'Accessories' Section.
4. Short contact tip life.	<ol style="list-style-type: none"> 1. Contact tip size. 2. Electrode eroding contact tip. 3. Exceeding duty cycle. 	<ol style="list-style-type: none"> 1. Replace with proper size. 2. Inspect and/or change drive rolls. 3. Replace with properly rated Bernard torch.
5. Erratic arc.	<ol style="list-style-type: none"> 1. Worn contact tip. 2. Buildup inside of liner. 3. Wrong tip size. 4. Not enough bend in neck. 	<ol style="list-style-type: none"> 1. Replace. 2. Replace liner, check condition of electrode. 3. Replace with correct size tip. 4. Replace with 45° or 60° neck.
6. Erratic wire feeding.	<ol style="list-style-type: none"> 1. Buildup inside of liner. 2. Wrong size liner. 3. Improper drive roll size. 4. Worn drive roll. 5. Improper guide tube relationship. 6. Improper wire guide diameter. 7. Gaps at liner junctions. 8. Feeder malfunction. 9. Contact tip. 	<ol style="list-style-type: none"> 1. Replace liner, check condition of electrode. 2. Replace with new liner of proper size. 3. Replace with proper size drive roll. 4. a. Replace with new drive roll. b. Stone edge of groove on drive roll. 5. a. Adjust/replace guide as close to drive rolls as possible. b. Eliminate all gaps in electrode path. 6. Replace with proper guide diameter. 7. a. Replace with new liner trimming as per 'Maintenance & Repair' (Section 5 & 8). b. Replace guide tube/liner, trim as close to mating component as possible. 8. Consult feeder manufacturer. 9. Inspect and replace.*

Part VI Troubleshooting Guide (cont.)

PROBLEM	POSSIBLE CAUSE	CORRECTIVE ACTION
7. Extreme spatter.	<ol style="list-style-type: none"> 1. Improper machine parameters. 2. Improper tip installation. 3. Improper shielding. 4. Contaminated wire or work piece. 	<ol style="list-style-type: none"> 1. Adjust parameters. 2. Adjust nozzle/tip relationship. 3. a. Verify shielding gas coverage. b. Verify gas mixture. 4. Clean wire and work piece.
8. Porosity in weld.	<ol style="list-style-type: none"> 1. Insulator worn. 2. Head damaged. 3. Extreme heat or duty cycle. 4. Solenoid faulty. 5. No gas. 6. Flow improperly set. 7. Gas ports plugged. 8. Ruptured gas hose. 9. Control circuit loss. 10. Worn, cut or missing o-rings. 11. Loose fittings. 	<ol style="list-style-type: none"> 1. Replace nozzle/insulator. 2. Replace head. 3. Replace with heavy duty consumables. 4. Replace solenoid. 5. a. Install full tanks. b. Check supply. c. Hose leaks. 6. Adjust. 7. a. Clean or replace gas diffuser/head. b. Clean nozzle. 8. Repair or replace cable or line. 9. See 'Electrode Does Not Feed'. 10. Replace o-rings 11. Tighten torch & cable connections to specified torque. See 'Maintenance & Repair' (Section 7).
9. Torch running hot.	<ol style="list-style-type: none"> 1. Exceeding duty cycle. 2. Loose or poor power connection. 1. a. Replace with properly rated Bernard torch. 	<ol style="list-style-type: none"> b. Decrease parameters to within torch rating. 2. a. Clean, tighten or replace cable grounding connection. b. Tighten torch & cable connections to specified torque. See 'Maintenance & Repair' (Section 7).
10. Liner is discolored full length.	<ol style="list-style-type: none"> 1. Short circuit to electrode. 2. Broken copper stranding in power cable. 	<ol style="list-style-type: none"> 1. Isolate electrode reel from feeder and drive block. Consult feeder manufacturers manual. 2. Replace Gun.
11. Sporadic feeding of aluminum electrode.	<ol style="list-style-type: none"> 1. Tip galling. 2. Synthetic liner melting. 3. Wire deformed by feed rolls. 	<ol style="list-style-type: none"> 1. Inspect & replace.* 2. a. Replace liner. b. Replace with composite liner. c. Replace with "Q" Gun body tube and jump liner. 3. Adjust drive rolls as per feeder manufacturer's manual.

*In some cases with aluminum and mild steels, it may be necessary to use a contact tip with either a larger or smaller bore size.

Notes