

Quik Tip™ Series

Nozzles, Tips, Diffusers

Issued Nov. 2009 • Index No. SPEC QT-2.0

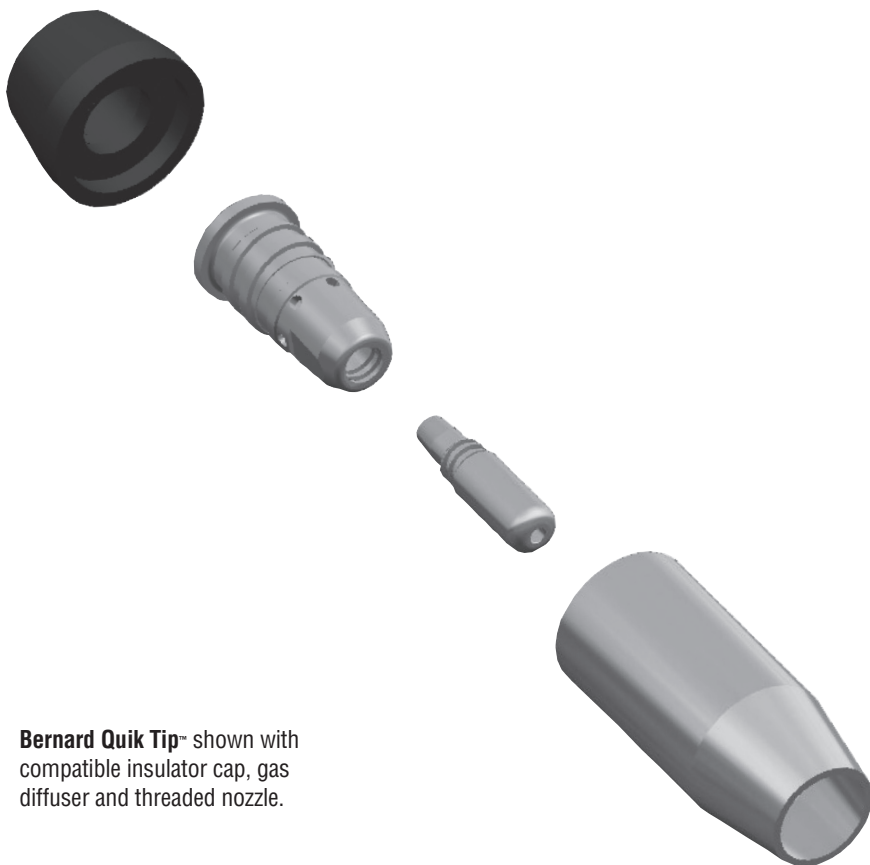

Bernard Quik Tip™ shown with compatible insulator cap, gas diffuser and threaded nozzle.

All Consumables are Not Created Equal.

It's important to choose longer lasting consumables. They can make the difference between repeated consumable replacement and rework, or more arc time and better bottom line.

Quik Tips designed with threaded taper lock that increases tip life by providing excellent heat transfer and electrical conductivity.

A quick twist is all it takes to install Quik Tips. In case of burn back, another quick twist will get you back on the job in moments.

Gas diffusers have positive stops to secure Quik Tips in a fixed position for superior repeatability and consistent, quality welds. Multiple fixed positions available.

Nozzles available in threaded and slip-on styles with a variety of orifice diameters for optimal shielding gas coverage.

Fit all Q-Guns™ and S-Guns™ - from 150 - 600 Amps.

Made with
Pride and without
Compromise in the **USA**

Bernard®

An Illinois Tool Works Company
449 West Corning Road, Box 667
Beecher, Illinois 60401 USA

Phone: 800-946-2281 (US Only) 708-946-2281 (Outside US)
Fax: 708-946-6726
For more information, visit us at BernardWelds.com



Available Parts

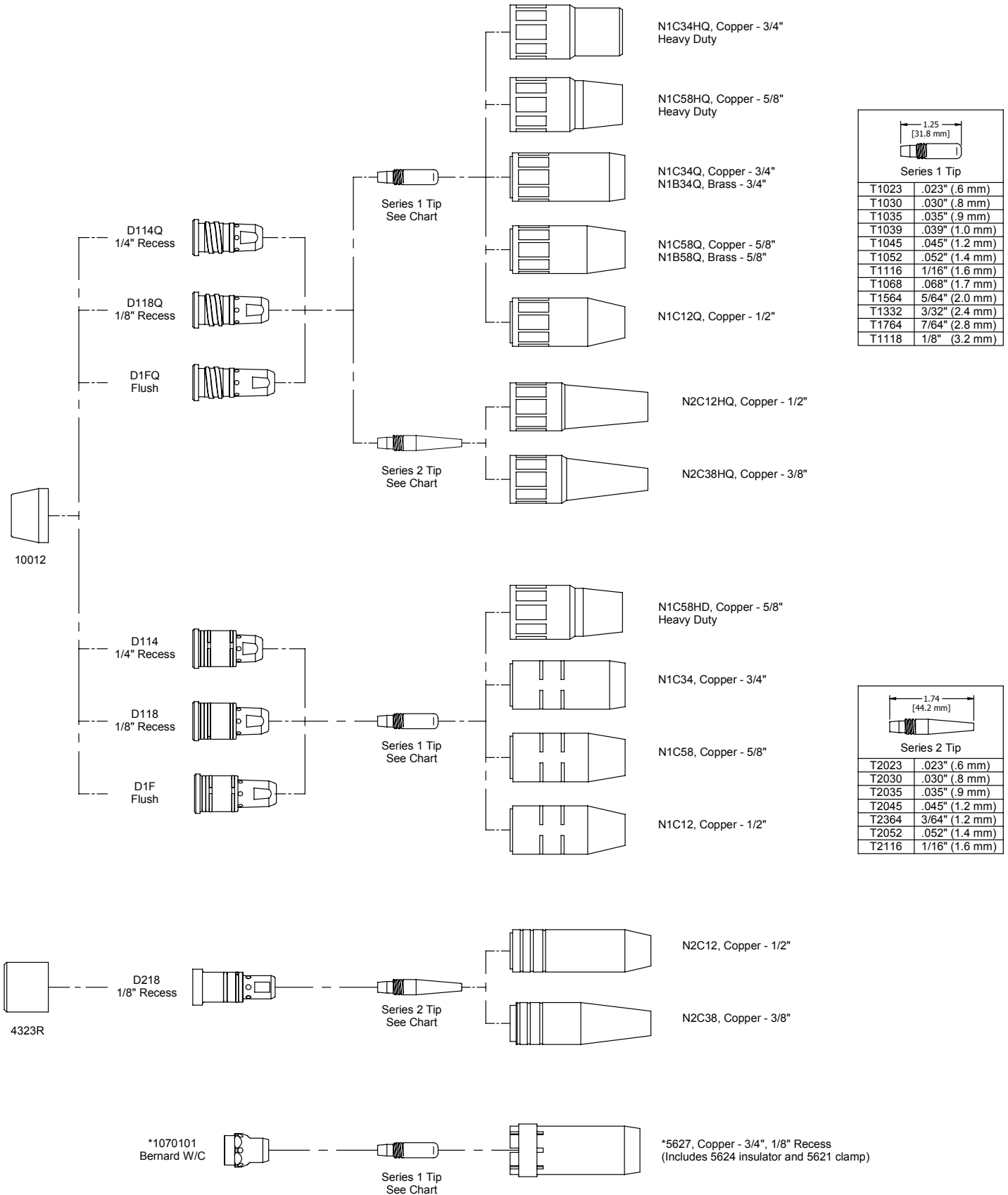

*For use with Bernard Water-Cooled guns.

Competitor Conversion

Simplify parts management and improve performance by converting all of your MIG guns to Quik Tip™ nozzles, contact tips and gas diffusers. Find your gun make and model on the left, then follow the chart to the right for parts needed to upgrade.

Slip-On Nozzles

Gun Manufacturer	Model	Adapter	Insulator	Gas Diffuser	Contact Tip	Nozzle
Tweco	No. 1 No. 2	1380005	10012	D1F D118 D114	Series 1 Quik Tips	N1C12 N1C58 N1C34 N1C58HD
	ELC250 ELC350 Spraymaster 250 Spraymaster 350	1380012				
	ELC 450 EL 450 EL 600 Supra XT (EL Consumables)	1380017				
Lincoln	Magnum 250	1380005				

Threaded Nozzles

Gun Manufacturer	Model	Adapter	Insulator	Gas Diffuser	Contact Tip	Nozzle
Tweco	No. 1 No. 2	1380005	10012	D1FQ D118Q D114Q	Series 1 Quik Tips	N1C12Q N1C58Q N1C34Q N1C58HQ N1C34HQ
	No. 3 No. 4 Tuff-N-Lite Supra XT (HD Consumables) Spraymaster 450	Not Required	VL1N	D118QLL		
	ELC250 ELC350 Spraymaster 250 Spraymaster 350	1380012	10012	D1FQ D118Q D114Q		
	ELC 450 EL 450 EL 600 Supra XT (EL Consumables)	1380017	10012	D1FQ D118Q D114Q		
Lincoln	Magnum 250	1380005	10012	D1FQ D118Q D114Q	Series 1 Quik Tips	N1C12Q N1C58Q N1C34Q N1C58HQ N1C34HQ
	Magnum 300 and 400	Not Required	VL1N	D118QLL		
Miller	M25	Not Required	10012	D118MQ	Series 1 Quik Tips	N1C12Q N1C58Q N1C34Q N1C58HQ N1C34HQ
Tregaskiss	Toughgun	Not Required	VL1N	D118QLL		

Quik Tip™ nozzles, tips and gas diffusers are manufactured by Bernard®. Bernard® is the registered trademark of Illinois Tool Works, Inc. Other brands mentioned are for reference only and are the registered trade marks of their respective companies. Illinois Tool Works, Inc. is not affiliated with these other companies.

Installation Instructions

Standard Installation:

1. Install insulator cap over neck.
2. Trim liner to correct dimension for diffuser being used (see Liner Trim Guidelines).
3. Torque diffuser onto neck to approx. 12ft-lbs.
4. Insert tip into gas diffuser and lock into position with a clockwise motion.
5. Thread nozzle onto gas diffuser and tighten firmly by hand.

Installation with Conversion Adapter:

1. Install conversion adapter.
2. Install insulator cap over conversion adapter.
3. Trim liner to correct dimension for diffuser being used (see Liner Trim Guidelines).
4. Torque diffuser onto neck to approx. 12ft-lbs.
5. Insert tip into gas diffuser and lock into position with a clockwise motion.
6. Thread nozzle onto gas diffuser and tighten firmly by hand.

Liner Trim Guidelines

- *Gas Diffusers with flush tips* – Trim 1" beyond neck thread.
- *Gas Diffusers with 1/8" tip recess* – Trim 7/8" beyond neck thread.
- *Gas Diffusers with 1/4" tip recess* – Trim 3/4" beyond neck thread.

